

**VARIABLE FREQUENCY DRIVES  
THEORY, APPLICATION, AND  
TROUBLESHOOTING**

BY

**HOWARD W. PENROSE  
UNIVERSITY OF ILLINOIS AT CHICAGO  
ENERGY RESOURCES CENTER  
851 SOUTH MORGAN STREET  
ROOM 1213, SEO, MC156  
CHICAGO, IL 60607**

1.0	Introduction .....	3
2.0	Alternating Current Induction Motor Design.....	3
2.1	Introduction .....	3
2.2	The Purpose of Induction Motors.....	3
2.3	Induction Motor Construction.....	4
2.4	Operating Principles.....	5
2.5	Torque .....	6
2.6	NEMA Motor Design Classifications.....	6
2.7	Design E Motor Discussion .....	7
2.8	Electric Motor Insulation.....	8
2.9	Energy Efficient Electric Motors .....	9
2.10	Inverter Duty Motors.....	10
3.0	Variable Frequency Drives.....	11
3.1	Variable Torque Loads.....	11
3.2	Constant Torque Loads.....	12
3.3	Basic Drive System .....	12
3.4	Basic Operation of a PWM Inverter (VFD).....	13
4.0	Application Considerations .....	14
4.1	Variable Speed Concerns.....	14
4.2	Power Quality .....	15
4.3	Inverter Duty Failures .....	16
5.0	Troubleshooting Drives.....	17

## 1.0 Introduction

In this presentation, we will be covering Variable Frequency Drives (VFD's) and their theory, application, and troubleshooting. In order to properly cover the subject, it will be broken into four distinct parts: Induction motor theory; VFD theory; Power quality; and Troubleshooting.

## 2.0 Alternating Current Induction Motor Design

### 2.1 Introduction

Electric motor systems consume 20% of all energy generated in the United States, 57% of all electrical energy, and 70% of electrical energy consumed by industry. Over 1.1 billion motors, of all types, are presently in use in the United States at this time.

Induction motors were invented by Nikola Tesla in 1888 while he was a college student. In the present day, induction motors consume between 90 to 95 percent of the motor energy used in industry.

In the first part of our presentation, we are going to discuss:

- ❑ The purpose of induction motors
- ❑ Induction motor construction
- ❑ Operating principles
- ❑ NEMA Designs
- ❑ Design E motor discussion
- ❑ Motor insulation
- ❑ Inverter duty motor construction

### 2.2 The Purpose of Induction Motors

Contrary to popular belief, induction motors consume very little electrical energy. Instead, they convert electrical energy to mechanical torque (energy). Interestingly enough, the only component more efficient than the motor, in a motor system, is the transformer. The mechanical torque that is developed by the electric motor is transferred, via coupling system, to the load.

The electrical energy that is consumed by electric motors is accounted for in losses. There are two basic types of losses, Constant and Variable, both of which develop heat (Figure 1):

- ❑ Core Losses: A combination of eddy-current and hysteresis losses within the stator core. Accounts for 15 to 25 percent of the overall losses.

- ❑ Friction and Windage Losses: Mechanical losses which occur due to air movement and bearings. Accounts for 5 to 15 percent of the overall losses.
- ❑ Stator Losses: The  $I^2R$  (resistance) losses within the stator windings. Accounts for 25 to 40 percent of the overall losses.
- ❑ Rotor Losses: The  $I^2R$  losses within the rotor windings. Accounts for 15 to 25 percent of the overall losses.
- ❑ Stray Load Losses: All other losses not accounted for, such as leakage. Accounts for 10 to 20 percent of the overall losses.

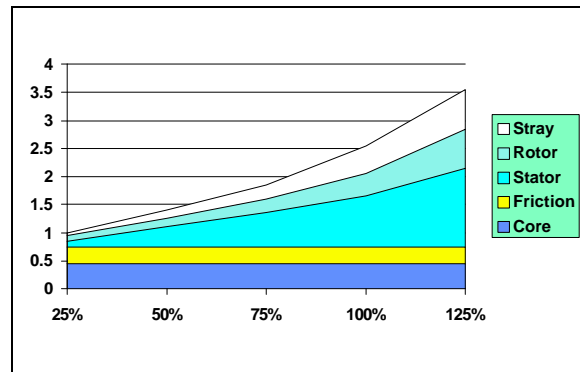

### 2.3 Induction Motor Construction

An induction motor consists of three basic components:

- ❑ Stator: Houses the stator core and windings. The stator core consists of many layers of laminated steel, which is used as a medium for developing magnetic fields. The windings consist of three sets of coils separated by 120 degrees electrical.
- ❑ Rotor: Also constructed of many layers of laminated steel. The rotor windings consist of bars of copper or aluminum alloy shorted, at either end, with shorting rings.
- ❑ Endshields: Support the bearings which center the rotor within the stator.



## 2.4 Operating Principles

The basic principle of operation is for a rotating magnetic field to act upon a rotor winding in order to develop mechanical torque.

The stator windings of an induction motor are evenly distributed by 120 degrees electrical. As the three phase current enters the windings, it creates a rotating magnetic field within the air gap (the space between the rotor and stator laminations). The speed that the fields travel around the stator is known as synchronous speed ( $N_s$ ). As the magnetic field revolves, it cuts the conductors of the rotor winding and generates a current within that winding. This creates a field which interacts with the air gap field producing a torque. Consequently, the motor starts rotating at a speed  $N < N_s$  in the direction of the rotating field.

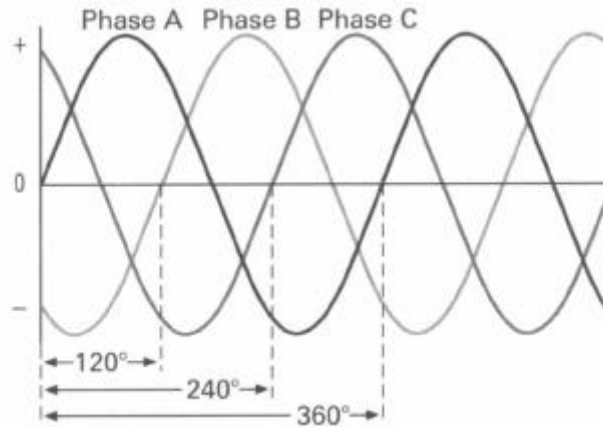

The speed of the rotating magnetic field can be determined as:

$$N_s = (120 * f) / p \quad \text{eq. 1}$$

Where  $N_s$  is the synchronous speed,  $f$  is the line frequency, and  $p$  is the number of poles found as:

$$p = (\# \text{ of groups of coils}) / 3 \quad \text{eq. 2}$$

The number of poles is normally expressed as an even number.

The actual output speed of the rotor is related to the synchronous speed via the slip, or percent slip:

$$s = (N_s - N) / N_s \quad \text{eq. 3}$$

$$\%s = s * 100 \quad \text{eq. 4}$$

## 2.5 Torque

By varying the resistance within the rotor bars of a squirrel cage rotor, you can vary the amount of torque developed. By increasing rotor resistance, torque and slip are increased. Decreasing rotor resistance decreases torque and slip.

Motor horsepower is a relation of motor output speed and torque (expressed in lb-ft):

$$\text{HP} = (\text{RPM} * \text{Torque}) / 5250 \quad \text{eq. 5}$$

The operating torques of an electric motor are defined as (Ref. NEMA MG 1-1993, Part 1, p.12):

- Full Load Torque: The full load torque of a motor is the torque necessary to produce its rated horsepower at full-load speed. In pounds at a foot radius, it is equal to the hp times 5250 divided by the full-load speed.
- Locked Rotor Torque: The locked-rotor torque of a motor is the minimum torque which will develop at rest for all angular positions of the rotor, with rated voltage applied at rated frequency.
- Pull-Up Torque: The pull-up torque of an alternating current motor is the minimum torque developed by the motor during the period of acceleration from rest to the speed at which breakdown torque occurs. For motors which do not have a definite breakdown torque, the pull-up torque is the minimum torque developed up to rated speed.
- Breakdown Torque: The breakdown torque of a motor is the maximum torque which it will develop with rated voltage applied at rated frequency, without an abrupt drop in speed.

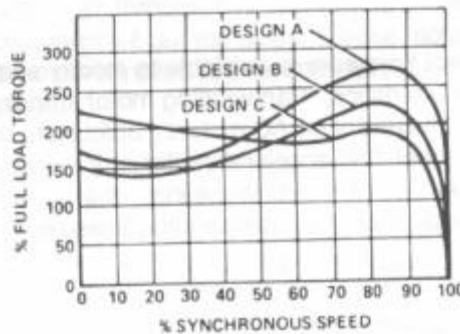

## 2.6 NEMA Motor Design Classifications

NEMA defines, in NEMA MG 1-1993, four motor designs dependant upon motor torque during various operating stages:

- Design A: Has a high starting current (not restricted), variable locked-rotor torque, high break down torque, and less than 5% slip.
- Design B: Known as "general purpose" motors, have medium starting currents (500 -

800% of full load nameplate), a medium locked rotor torque, a medium breakdown torque, and less than 5% slip.

- Design C: Has a medium starting current, high locked rotor torque (200 - 250% of full load), low breakdown torque (190 - 200% of full load), and less than 5% slip.
- Design D: Has a medium starting current, the highest locked rotor torque (275% of full load), no defined breakdown torque, and greater than 5% slip.

Design A and B motors are characterized by relatively low rotor winding resistance. They are typically used in compressors, pumps, fans, grinders, machine tools, etc.

Design C motors are characterized with dual sets of rotor windings. A high resistive rotor winding, on the outer, to introduce a high starting torque, and a low resistive winding, on the inner to allow for a medium breakdown torque. They are typically used on loaded conveyers, pulverizers, piston pumps, etc.

Design D motors are characterized by high resistance rotor windings. They are typically used on cranes, punch presses, etc.

## 2.7 Design E Motor Discussion

The design E motor was specified to meet and international standard promulgated by the International Electrotechnical Commission (IEC). IEC has a standard which is slightly less restrictive on torque and starting current than the Design B motor. The standard allows designs to be optimized for higher efficiency. It was decided to create a new Design E motor which meets both the IEC standard and also an efficiency criterion greater than the standard Design B energy efficient motors.

For most moderate to high utilization application normally calling for a Design A or B motor, the Design E motor should be a better choice. One should be aware of slight performance differences.

Although the NEMA standard allows the same slip (up to 5%) for Designs A, B, and E motors, the range of actual slip of Design E motors is likely to be lower for Designs A and B.

There are a number of considerations which must be observed with Design E motors:

- Good efficiency - as much as 2 points above Design B energy efficient.
- Less Slip - Design E motors operate closer to synchronous speed.
- Lower Starting Torque - May not start "stiff" loads.
- High Inrush - As much as 10 times nameplate full load amps.
- Availability - Presently low as the standard has just passed.
- Starter Availability - Control manufacturers do not have an approved starter developed at this time.
- National Electric Code - Has no allowance for higher starting amps. Design E motors will require changes to NEC allowances for wire size and feed transformers.

- ❑ Limited Applications - Low starting torque limits applications to pumps, blowers, and loads not requiring torque to accelerate load up to speed.
- ❑ Heavier Power Source Required - High amperage and low accelerating torque mean longer starting time and related voltage drops. May cause nuisance tripping of starter or collapse of SCR field with soft starters.

## 2.8 Electric Motor Insulation

With all this discussion about motor operation, losses, torque curves, and inrush, it is only fitting to review the thermal properties of electrical insulation. In general, when an electric motor operates, it develops heat as a by-product. It is necessary for the insulation that prevents current from going to ground, or conductors to short, to withstand these operating temperatures, as well as mechanical stresses, for a reasonable motor life.

Insulation life can be determined as the length of time at temperature. On average, the thermal life of motor insulation is halved for every increase of operating temperature by 10 degrees centigrade (or doubled, with temperature reduction).

Table 2: Maximum Temperatures of Common Insulation Classes

Insulation Class	Temperature, °C
A	105
B	130
F	155
H	180

There are certain temperature limitations for each insulation class (Table 3) which can be used to determine thermal life of electric motors. Additionally, the number of starts a motor sees will also affect the motor insulation life. These can be found as mechanical stresses and as a result of starting surges.

When a motor starts, there is a high current surge (as previously described). In the case of Design B motors, this averages between 500 to 800% of the nameplate current. There is also a tremendous amount of heat developed within the rotor as the rotor current and frequency is, initially, very high. This heat also develops within the stator windings.

In addition to the heat developed due to startup, there is one major mechanical stress during startup. As the surge occurs in the windings, they flex inwards towards the rotor. This causes stress to the insulation at the points on the windings that flex (usually at the point where the windings leave the slots).

Both of these mean there are a limited number of starts per hour (Figure 4). These limits are general, the motor manufacturer must be contacted ( or it will be in their literature)

for actual number of allowable starts per hour. this table also assumes a Design B motor driving a low inertia drive at rated voltage and frequency. Stress on the motor can be reduced, increasing the number of starts per hour, when using some type of "soft start" mechanism (autotransformer, part-winding, electronic soft-start, etc.).

Table 3: Temperature Limitations

Service Factor	Insulation Temperature	Class B	Class F
1.0/1.15	Ambient	40C 104F	40C 104F
1	Allowable Rise	80C 176F	105C 221F
1	Operating Limit	120C 248F	145C 293F
1.15	Allowable Rise	90C 194F	115C 239F
1.15	Operating Limit	130C 266F	155C 311F

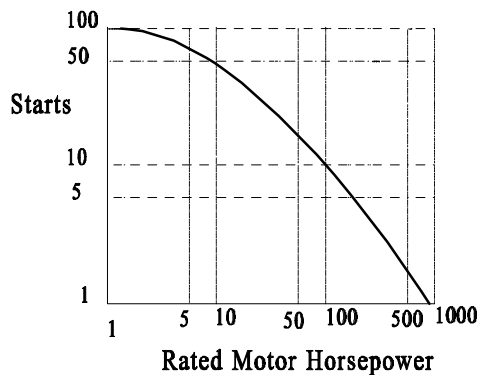

Figure 4: Allowable Number of Starts per Hour

## 2.9 Energy Efficient Electric Motors

The Energy Policy Act of 1992 (EPACT) directs manufacturers to manufacture only energy efficient motors beyond October 24, 1997 for the following: (All motors which)

- General Purpose
- Design B
- Foot Mounted
- Horizontal Mounted
- T-Frame
- 1 to 200 hp
- 3600, 1800, and 1200 RPM

- Special and definite purpose motor exemption

To meet NEMA MG1-1993 table 12.10 efficiency values. The method for testing for these efficiency values must be traceable back to IEEE Std. 112 Test type B.

Energy efficient motors are really just better motors, when all things are considered. In general, they use about 30% more lamination steel, 20% more copper, and 10% more aluminum. The new lamination steel has about a third of the losses than the steel that is commonly used in standard efficient motors.

As a result of fewer losses in the energy efficient motors, there is less heat generated. On average, the temperature rise is reduced by 10 degrees centigrade, which has the added benefit of increasing insulation life. However, there are several ways in which the higher efficiency is obtained which has some adverse effects:

- Longer rotor and core stacks - narrows the rotor - Reduces air friction, but also decreases power factor of the motor (more core steel to energize - kVAR).
- Smaller fans - reduces air friction - the temperature rise returns to standard efficient values.
- Larger wire - Reduces  $I^2R$ , stator losses - Increases starting surge (half - cycle spike) from 10 to 14 times, for standard efficient, to 16 to 20 times, for energy efficient. This may cause nuisance tripping.

In general, energy efficient motors can cost as much as 15% more than standard efficient motors. The benefit, however, is that the energy efficient motor can pay for itself when compared to a standard efficient motor.

$$\$ = 0.746 * hp * L * C * T (100/E_s - 100/E_e)$$

where hp = motor hp, L = load, C = \$/kWh, T= number of hours per year, Es = Standard efficient value, and Ee = Energy efficient value Eq. 5

## 2.10 Inverter Duty Motors

Inverter duty motors are specially designed to withstand the new challenges presented by the use of inverters. There are a number of ways to designate motors "inverter duty," however, several things must exist as a minimum:

- Class F insulation - to withstand the higher heat generated by non-sinusoidal current from the drive.
- Phase insulation - Insulation between phases is a must to avoid "flashover" between phases from current surges.
- Layered Conductors - To reduce turn to turn potential between conductors.
- Solid varnish system - to reduce partial discharge and corona damage.
- Tight machine tolerances and good air gap concentricity - to reduce shaft currents and resulting bearing damage.

A proper inverter duty motor will have special rotor bar construction designed to withstand variations in airgap flux densities and rotor harmonics. Additionally, the first few turns of wire may be insulated to better withstand standing waves which occur due to the faster rise times in modern inverter technology.

Caution: Some manufacturers may only de-rate motors. This is done by reducing the motor by (about) 25%. Therefore, a 10 hp motor may be rated as a 7.5 hp motor.

It should be noted, also, that an inverter application does not always require an inverter duty motor. The old motor or an energy efficient motor may be sufficient for the application.

### 3.0 Variable Frequency Drives

#### 3.1 Variable Torque Loads

Variable loads offer a tremendous opportunity for energy savings with AFD's. The areas of greatest opportunity are fans and pumps with variable loads.

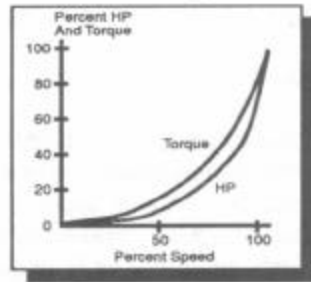

Fan and pump applications are the best opportunities for direct energy savings with AFD's. Few applications require 100% of pump and fan flow continuously. For the most part, these systems are designed for worst case loads. Therefore, by using AFD's, fluid affinity laws can be used to reduce the energy requirements of the system (Fig. 3).

Fig.3 Pump and Fan Affinity Laws

$$\begin{aligned} \text{Eq. 1: } N1 / N2 &= \text{Flow1} / \text{Flow2} \\ \text{Eq. 2: } (N1 / N2)^2 &= \text{Head1} / \text{Head2} \\ \text{Eq. 3: } (N1 / N2)^2 &= T1 / T2 \\ \text{Eq. 4: } (N1 / N2)^3 &= \text{HP1} / \text{HP2} \end{aligned}$$

By using the affinity laws, you can determine the approximate energy savings:

Ex. 1: 250hp Fan Operating 160 hrs / Week

$$hp1 / hp2 : (N1 / N2)^3$$

$100\% \text{ spd} = 40 \text{ hrs} = 100\% \text{ ld} = 250\text{hp}$   
 $75\% \text{ spd} = 80 \text{ hrs} = 42\% \text{ ld} = 105\text{hp}$   
 $50\% \text{ spd} = 40 \text{ hrs} = 13\% \text{ ld} = 31\text{hp}$

$$kWh / wk = (hp) \times (0.746) \times (hrs / \text{eff})$$

$$250 \times 0.746 \times (160 / 0.95) = 31,411\text{kWh/wk}$$

Assuming no loss of efficiency at reduced speeds:

$$(250 \times 0.746 \times (40/0.95)) + (105 \times 0.746 \times (80/0.95)) + (31 \times 0.746 \times (40/0.95)) = 15,422 \text{ kWh}$$

By using an AFD the approximate kWh savings per year would look like:

$$(31,411 - 15,422) \times 50 = 800,000 \text{ kWh/yr}$$

### 3.2 Constant Torque Loads

Direct Current electric motors, eddy-current clutches, transmissions, etc. used to be the best way of controlling process speed. With present AC drive technology, greater speed control and fewer losses can be realized. Additionally, there are fewer moving parts that would have to be maintained.

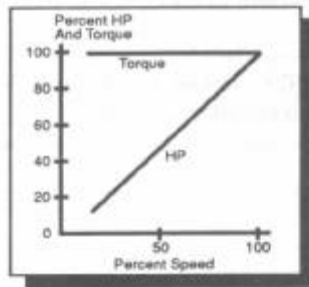

Vector drives can deliver full rated torque from full speed to zero RPM. Torque can be controlled, with precision, allowing even large motors to position loads much like servo motors. This allows for greater flexibility of control over the other methods of speed control.

### 3.3 Basic Drive System

The AFD consists of several basic components:

- Line Voltage - In this case 3-phase AC voltage.
- Input Section - Consists of a rectifier and filter. Transforms the AC voltage into DC

voltage.

- Control Section - The control board accepts real world inputs and performs the required operations. The tasks are performed by a microprocessor.
- Output Section - This section includes the base drive circuits and the inverter. The base drive signals are low level signals that tell the inverter to turn on.
- Motor - Already described.

### 3.4 Basic Operation of a PWM Inverter (VFD)

In this section we will discuss how the five basic drive system components work together. After this discussion we shall include a detailed, component level, discussion of operation.

The rectifier circuit of a pulse width modulated drive normally consists of a three phase diode bridge rectifier and capacitor filter. The rectifier converts the three phase AC voltage into DC voltage with a slight ripple (Figure 5). This ripple is removed by using a capacitor filter. (Note: The average DC voltage is higher than the RMS value of incoming voltage by:  $AC (RMS) \times 1.35 = VDC$ )

The control section of the AFD accepts external inputs which are used to determine the inverter output. The inputs are used in conjunction with the installed software package and a microprocessor. The control board sends signals to the driver circuit which is used to fire the inverter.

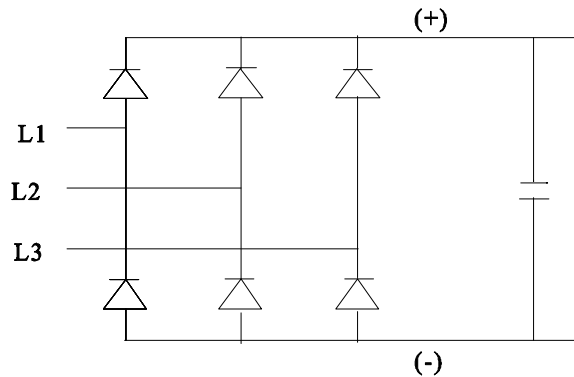

**Fig. 3: Rectifier and Filter**

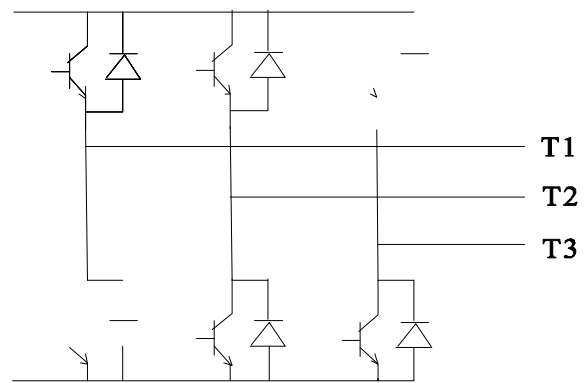

**Fig. 6: Inverter Section**

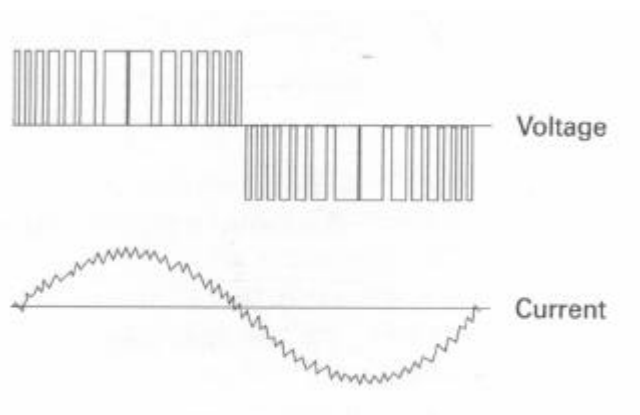

The driver circuit sends low-level signals to the base of the transistors to tell them when to turn on. The output signal is a series of pulses (Figure 7), in both the positive and negative direction, that vary in duration. However, the amplitude of the pulses are the same. The sign wave is created as the average voltage of each pulse, the duration of each set of pulses dictates the frequency.

By adjusting the frequency and voltage of the power entering the motor, the speed and torque may be controlled. The actual speed of the motor, as previously indicated, is determined as:  $N_s = ((120 \times f) / P) \times (1 - S)$  where: N = Motor speed; f = Frequency (Hz); P = Number of Poles; and S = Slip.

## **4.0 Application Considerations**

### **4.1 Variable Speed Concerns**

Whenever load speeds are varied, there are many considerations which must be taken into account. These concerns are both electrical and mechanical in nature.

The electrical problems associated with electronic drives generally concern the insulation. Because of the type of output generated by the inverter, there is great stress placed upon the insulation and the temperature rise of the windings may increase. In other cases, the motor may be run below its minimum self-cooling speed. The main trouble is that for every 10 degrees C, the insulation life of the windings are reduced by half. If the temperature rise is allowed to climb too high, the motor will overload and burn-up in a very short time. An additional problem, which is rare, is inverter resonance. These difficulties can be avoided through the following means:

- Rewind or replace the motor - Rewind the motor to a higher insulation class, or replace it with a new motor. the new motor may be of the energy efficient or inverter duty type.
- Provide external cooling - This is especially important in cases where the self-cooling ability of the motor is compromised.
- Re-set the parameters - inverter resonance is found in cases where the drive parameters are not properly set. If this is not the case, the drive should be programmed to by-pass those frequencies where the problems are found.

Mechanical considerations include mechanical resonance and driven load incompatibility. Mechanical resonance can be defined as the speed of the driven load that matches its natural frequency. If this speed is found and maintained, the equipment will develop extremely high levels of vibration and may shake itself apart. Load incompatibility can be defined as loads which may not be operated at speeds lower than their design speed. For instance, many gearboxes have a minimum speed at which the lubricating oil may not be properly moved over the contacting parts.

Mechanical resonance can be avoided by programming the drive to avoid the appropriate frequency(s). The resonance levels may be determined by using a vibration analyzer and operating the machine through the entire speed range. Another way is by performing a "ring-test" using vibration analysis equipment. Load incompatibility can only be avoided by not allowing the drive to operate below a minimum speed.

#### 4.2 Power Quality

Harmonics and electrical noise are potential problems when power electronics are utilized. As more AFD's are put into use, utilities may force users to install harmonic filtering from entering their systems. IEEE Recommended Practices and Requirements for Harmonic Control in Electrical Power Systems; IEEE Std. 519 - 1992; is written to attend to this issue. The standard has been written to limit the harmonic content introduced into the system by either the utilities or the customer.

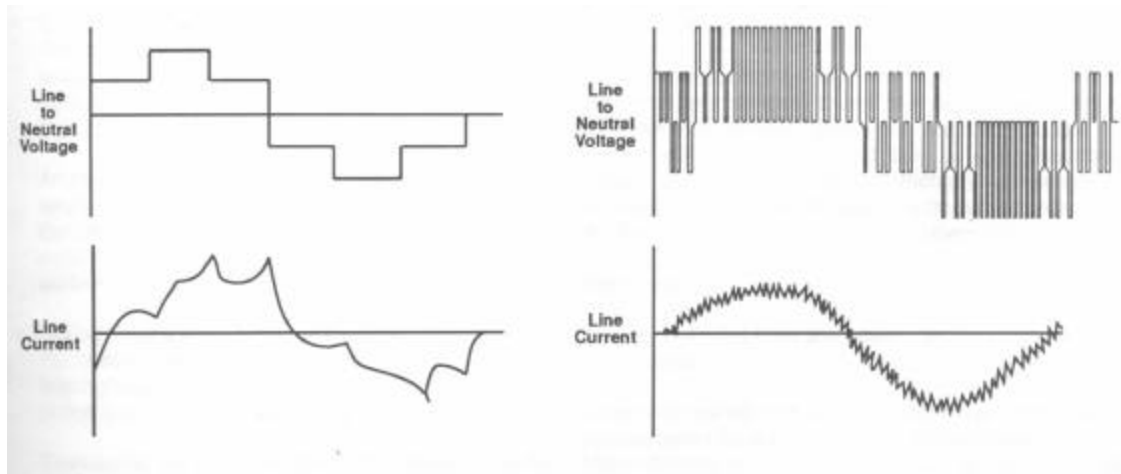

(Note: The limits are, generally, 5% voltage distortion and 3% current distortion at the Point of Common Connection (PCC) or the point at which the utility power enters the customer plant.)

Harmonic content has attracted quite a bit of attention when discussing power quality and power electronics. Harmonics, created by the load, generally come from feedback into the line from electronic power supplies. Voltage and current harmonics tend to create alternate fields within motors and rotors, cause transformers to overheat, and interfere with other electronic systems. Odd harmonics of the fundamental frequency are generally found in power electronic systems.

In motor systems the following fundamentals of 60 Hz can be recognized:

Harm:	1st	3rd	5th	7th	etc.
Rot:	pos.	zero	neg.	pos.	etc.

Fig. 8: Voltage and Current Harmonics

Positive harmonics rotate in the direction of the rotor. Other than the fundamental frequency, this type of harmonic causes heating within the stator. Negative rotating harmonics rotate against the rotor causing overheating of the rotor and reducing torque. Zero rotating harmonics generally cause system neutrals to overheat. In the case of electronic drives, in general, the predominant harmonics are the 5th and 7th.

### 4.3 Inverter Duty Failures

It has been documented that some electric motors fail in inverter applications. This has often been attributed to inverter voltage “spikes.” While this is relatively correct, it misses some important aspects to the mode of failure.

The number of pulses that a PWM drive fires in order to control the current waveform to the drive is known as the carrier frequency. The carrier frequency tends to run from 2 to 18 kHz in most modern PWM drive. In addition, each voltage pulse is not a square waveform. They have a tendency to overshoot on startup, causing a “ringing” effect at the peak voltage of the pulse. Insulation systems are designed, not only for temperature, but also for “rise time,” how fast the voltage increases over time.

Initially, it was thought that inverter duty failures occurred only on the first few turns of the electric motor winding. It was later found that this was not correct for all cases. Instead, it was discovered, a phenomenon normally seen in electric motors rated at 6,000 VAC, and above, known as Partial Discharge, was now occurring in motors rated as low as 460VAC. This phenomenon is similar to a lightning storm within the windings themselves. Within voids in the winding insulation, charges build up, then discharge (much like a capacitor). The end result is ozone, which begins to break down the insulation on the wires, eventually causing a current path, or short.

The mode of failure for motors in this environment is as follows:

- The motor and drive are placed a distance apart and the carrier frequency is set high (ie: above 8kHz) in order to keep the motor quiet. The lower the carrier frequency the louder the motor noise. No filtering is put in place.
- The pulses from the drive travel out to the motor. Based upon the impedance of the cable and motor, a reflection of the pulse travels back to the drive. This cycles through the “free-wheeling” diodes of the inverter and travel back out with the normal pulses. This adds on to the peak voltage, causing a greater peak (as much as 2 to 4 times, usually 2) with an extremely fast rise time. (ie: less than .1 u-sec per 500 V versus the 1 u-sec per 500 V recommended by NEMA).
- In some cases, the voltage spikes will cause the weakest part of the winding insulation to fail and the motor shorts.
- In other cases, small voids in the insulation begin to have partial discharge problems, the ozone eats away at the insulation, until, finally, the insulation becomes weak enough for the spikes to break through.

It should be pointed out that this tends to be a rare problem. Following are measures to avoid the chance of this problem occurring to you:

- Check with the motor manufacturer to ensure that the motor can operate in an inverter environment.
- Use filters in the inverter system (ie: from line reactors to spike arrestors, designed for inverter use).
- Read the VFD operators manual. It will often state the minimum distances and frequency settings.
- Use proper wire sizes.

## 5.0 Troubleshooting Drives

“If you are not using an oscilloscope, you are not troubleshooting your drive.”- me

### Common Problems:

Problem	Possible Cause	Solutions
The motor will not run	No line power; drive output too low; stop command present; no run or enable command; faulty drive	Check circuit breakers and drive programming. Check for other permissions
Overcurrent or sustained overload	Incorrect overload setting; motor is overloaded	Check overload settings and check to ensure motor is not overloaded
Motor stalls or transistor trip occurs	Acceleration time may be too short. High inertia load.	Lengthen acceleration time. Readjust the V/Hz pattern
Overvoltage	The DC bus voltage has reached too high a level	Deceleration time too short or the supply voltage is too high; motor overhauled by load.
Speed at motor is not correct; speed is fluctuating	Speed reference is not correct; speed reference might be carrying interference	Ensure that the reference is correct and clean.